

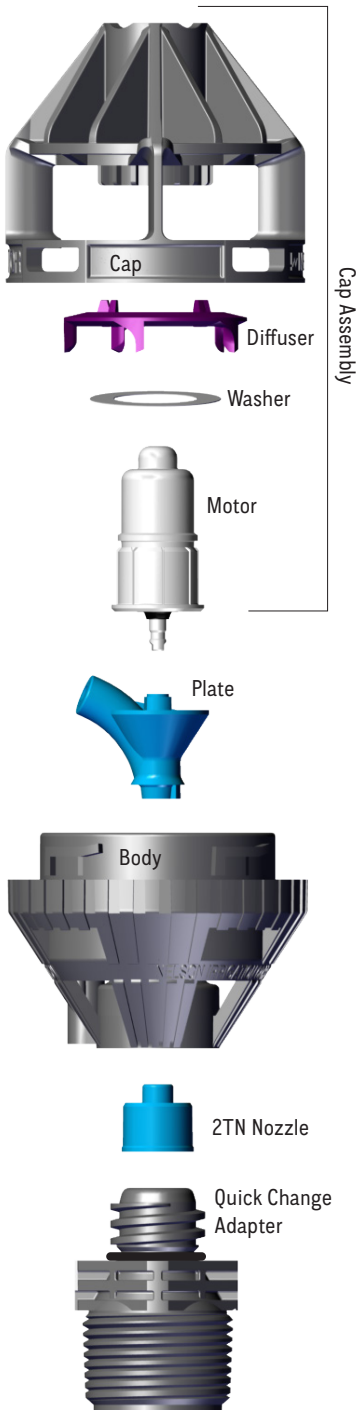

ROTATOR® FAMILY OF SPRINKLERS



R2000WF/LP

DISASSEMBLY/REPAIR INSTRUCTIONS

GENERAL DISASSEMBLY

1. **REMOVE THE SPRINKLER** from the ACME thread of the quick change adapter.
2. **SEPARATE THE CAP FROM THE BODY** by squeezing the release points (the words SQUEEZE) while turning counter-clockwise. For easy removal, use the #10689 Cap Removal Tool. Position the tool (as shown on the right) to apply pressure to the words SQUEEZE.



3. Use the #12260 2TN Nozzle Removal Tool to **REMOVE THE 2TN NOZZLE** from the body. Place the tool at the top of the R2000WF body and press down. The nozzle should easily pop out.

WARNING: Always use the #12260 tool to remove a 2TN nozzle from a R2000WF Rotator. Never use a stick, rod, or any other object to push on the outlet of the 2TN nozzle to remove. This can easily damage the plate bearing surface and cause rotation failure.

4. **REMOVE THE PLATE** by placing your fingers in the open space in the cap (between the washer and plate). Pull towards you until the plate pops up away from the cap.

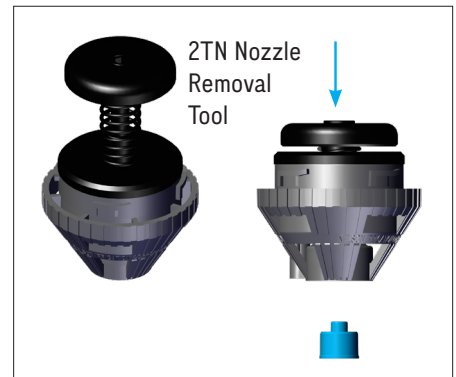

5. **REMOVE THE MOTOR** from the cap by fitting the Motor Removal Tool #12215 onto the top of the cap.
 - (1) Press on the outer ring of the motor removal tool so it fits tightly against the cap.
 - (2) Press on the inner circle of the tool so the motor disengages from the cap. Gently push the motor from the top to completely remove it from the cap assembly.

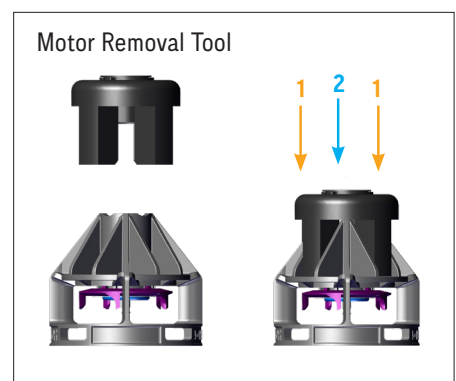

ALWAYS BE SURE

- The Nozzle size is recommended for the plate.
- Operating pressures are between 40 and 65 PSI (2.8 to 4.5 BAR)
- Proper assembly is essential to product satisfaction.

GENERAL ASSEMBLY

- SELECT THE NEW PARTS** — nozzle, plate and/or motor that will be used in the assembly. Always be sure the nozzle size is recommended for the plate and the motor. See graph on right.
- While holding the cap in one hand, **INSTALL THE MOTOR** by first setting the diffuser in place (small teeth against the ridges in the cap) and topping it off with the washer. Direct the motor into the hole of the cap assembly. Align the hole of the Motor Assembly Tool (the disc that ships with part #12215) on the shaft of the motor and snap motor into place.
- Next, **ASSEMBLE THE PLATE TO THE CAP ASSEMBLY**. Place the cap assembly in one hand and the WF Plate in the other. Orient the two components so the flats of the motor shaft and plate are parallel as shown below. Gently push the plate onto the shaft. The plate is correctly installed once you have felt two distinct “clicks” as you push the plate on. Do not continue pushing after you have felt the plate snap into place. Damage to the plate and/or other parts may occur, resulting in unsatisfactory sprinkler operation.
- CONNECT THE CAP/PLATE ASSEMBLY TO THE BODY** by holding the body in one hand and fastening the cap/assembly with a clockwise turn of the other hand.
- PLACE A 2TN NOZZLE INTO THE BASE OF THE WF BODY** with the small end of the nozzle pointed towards the cap.
- PLACE A QUICK CHANGE ADAPTER INTO THE BASE OF THE BASE OF THE BODY** and turn clock-wise. Confirm that there is a o-ring in place. Assembly is now complete.

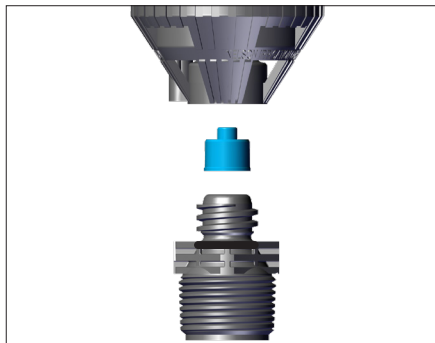
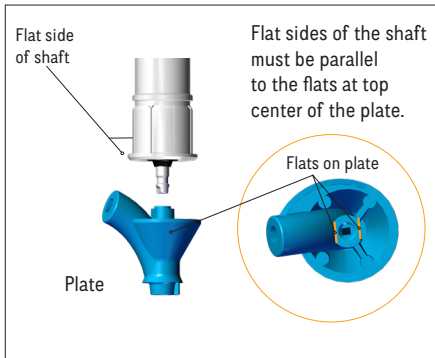
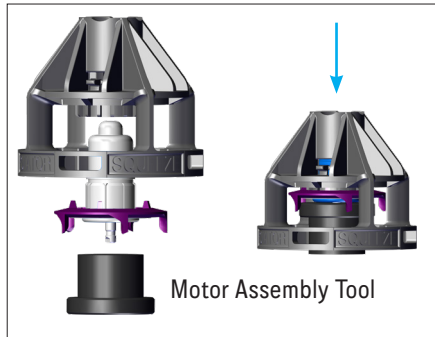

SPRINKLER LESS ADAPTER

PLATE	NOZZLE	COMPLETE R2000WF CAP & BODY ASSY	WF MOTOR COLOR	COMPLETE R2000LP CAP & BODY ASSY	LP MOTOR COLOR
10	10	9928-1010	Purple	9929-1010	Green
12	11	9928-1211	Ivory	9929-1211	Green
	12	9928-1212	Ivory	9929-1212	Green
14	13	9928-1413	Ivory	9929-1413	Purple
	14	9928-1414	Ivory	9929-1414	Purple
16	15	9928-1615	Ivory	9929-1615	Purple
	16	9928-1616	Ivory	9929-1616	Purple
18	18	9928-1818	Ivory	9929-1818	Purple
20	20	9928-2020	Ivory	9929-2020	Purple

WARRANTY AND DISCLAIMER: Nelson R2000WF Rotators are warranted for one year from the date of original sale to be free of defective material and workmanship when used within the working specifications for which the products were designed and under normal use and service. The manufacturer assumes no responsibility for installation, removal or unauthorized repair of defective parts and the manufacturer will not be liable for any crop or other consequential damages resulting from any defects or breach of warranty. THIS WARRANTY IS EXPRESSLY IN LIEU OF ALL OTHER WARRANTIES, EXPRESS OR IMPLIED, INCLUDING THE WARRANTIES OF MERCHANTABILITY AND FITNESS FOR PARTICULAR PURPOSES AND OF ALL OTHER OBLIGATIONS OR LIABILITIES OF MANUFACTURER. No agent, employee or representative of the manufacturer has authority to waive, alter or add to the provisions of this warranty nor to make any representations or warranty not contained herein. This product may be covered by one or more of the following U.S. Patent Numbers 4796811, RE33823, DES312865, 5058806, 5372307, 5875815 and other U.S. Patents pending or corresponding issued or pending foreign patents.



NELSON IRRIGATION CORPORATION

848 Airport Rd., Walla Walla, WA 99362 U.S.A.

Tel: 509.525.7660 Fax: 509.525.7907 info@nelsonirrigation.com

NELSON IRRIGATION CORPORATION OF AUSTRALIA PTY. LTD.

35 Sudbury Street, Darra QLD 4074

Tel: +61 7 3715 8555 Fax: +61 7 3715 8666 info@nelsonirrigation.com.au

NELSON IRRIGAÇÃO BRASIL LTDA.

Rua Benedita Mano Schincariol, 110 Santa Cruz, Mogi Mirim, SP 13800-443

Tel: +55 (19) 98816-4992 www.nelsonirrigation.com.br